

Multilin 345

Intuitive Transformer Protection

The Multilin™ 345 is a member of the Multilin 3 Series protective relay platform and has been designed for the protection, control and management of power transformers as the primary or backup protection device. The 345 provides advanced transformer protection, control and monitoring in one economical drawout or non-drawout design. The 345 contains a full range of self-contained protection and control elements as well as advanced communications, metering, monitoring and diagnostics.

Key Benefits

- Secure high-speed protection with improved energization inhibiting
- Field-proven algorithms and reliable protection to avoid unwanted trips or under-protection
- Integrated transformer thermal monitoring for asset management maintenance optimization
- Ground current supervised sensitive ground fault protection for detection of ground faults down to 5% of the winding
- Temperature monitoring via remote RTD's using the RMIO module supporting up to 12 RTDs
- Ease of use and flexibility with one-step setup, universal CT inputs and assignable CT inputs
- Flexible communications with multiple ports and protocols allowing seamless integration
- Powerful security and hierarchical password control for centralized management
- Drawout design simplifies testing, commissioning and maintenance, thereby increasing process uptime
- Application flexibility with the use of programmable logic elements
- Switchgear diagnostics and easy troubleshooting by trip/close circuit supervision and LED and Digital Output Test Mode
- Environmental monitoring system to monitor operating conditions and plan preventative maintenance
- Robust design exceeding industry standards, with Automotive Grade components and advanced testing procedures such as accelerated life cycle testing
- Drawout or non-drawout options available
- Simplified migration of legacy MII Family relays to the 3 Series platform
- Intuitive configuration software and user-friendly logic configuration tool

Applications

- Primary or backup protection of two winding power transformers
- Protection of reactors and autotransformers
- Protection for distribution transformers of various sizes and voltage levels
- Applications requiring fast and secure communications
- Protection against corrosion and humidity required for harsh environments



Protection and Control

- Dual slope with unique dual breakpoint differential protection with unrestrained differential
- Second harmonic inrush and fifth harmonic over-excitation inhibits
- Thermal Overload and restricted Ground Fault (RGF/87G)
- Comprehensive overcurrent elements
- Breaker failure and lockout functions

Metering & Monitoring

- Comprehensive metering
- Event Recorder: 256 events (1ms time stamping)
- Programmable oscillography up to 32 samples per cycle and, digital states and Fault Report
- Relay health diagnostics and Breaker monitoring
- Security and password control
- SNTP or IRIG-B time synchronization

Communications

- Front USB and rear serial, Copper and Fiber Ethernet ports
- Multiple communication protocols including IEC 61850, IEC 61850 GOOSE, Modbus® TCP/IP, Modbus RTU, DNP 3.0, IEC 60870-5-104, IEC 60870-5-103

EnerVista™ Software

- Simplified setup and configuration
- Strong document management system
- Full featured monitoring and data recording
- Maintenance and troubleshooting tool
- Seamless integration toolkit
- Setting conversion tool for MII Family to 3 Series



Overview

The 345 is a microprocessor-based system for primary or backup protection of two winding power transformers. The 345 also provides a very cost-effective differential solution for distribution transformers as well as backup protection for primary substations. The 345 offers advanced algorithms for automatic magnitude and phase compensations for more than twenty types of two-winding transformers, fast and secure biased differential protection with dual slope, and dual breakpoint characteristic. The 345 is equipped with restricted ground fault elements to detect ground faults down to 5% of the transformer winding, basic thermal protection and a full set of phase, ground, neutral and negative sequence over-current protection. The two identical groups with protection elements aim to satisfy these applications, where an automatic change of the settings is required.

The 345 provides excellent accessibility and transparency with regard to the power system conditions and events, through its target messaging and the four lines of 20 characters display, the Transient and Event Recorders, and the powerful EnerVista PC program.

Easy to Use

Drawout & Non-Drawout Construction

The 345 is offered in both a drawout and a non-drawout construction. In the drawout case design the 345 simplifies installation and improves site safety as the need to open switchgear doors or rewire the device after testing is eliminated. As communication cables remain connected to the chassis, even when the relay is withdrawn, communications status is retained.

The 345 protection relay chassis used with a drawout relay is available separately, for use as a partial replacement or in test environments. The drawout relay with no chassis is also available to order as a spare unit.

Application Flexibility & Ease of Wiring

Available universal CT inputs along with a software-configurable input range (1A and/or 5A) helps to standardize the design and reduce the number of order codes. There is also no need to change the entire relay in case of a design change or future switchgear modifications.

Mixed inputs of 1A or 5A are advantageous for applications where the ground CT is different from the phase CTs. Removable terminals ease wiring and in-system testing or troubleshooting.

Effortless Retrofit

The compact and withdrawable feature of the 345 relay minimizes mounting requirements, enables easy retrofit to existing cases, and allows multiple relays to be mounted side by side on a panel. The 345 also provides a pluggable RS485 & IRIG-B connection for easy troubleshooting.

Fast & Simple Configuration

With quick setup screens the 345 requires minimal configuration for standard transformer protection applications. Utilizing the powerful EnerVista 3 Series setup software, device configuration can be completed in one easy step.

Advanced Communications

Easy integration into new or existing infrastructure

With several Ethernet and serial port options, and a variety of protocols, the 345 provides advanced and flexible communication selections for new and existing energy management, SCADA and DCS systems.

345 Relay Features

✓ Easy to Configure- 1 Simple Step



✓ Advanced & Flexible Communication Options



Non-drawout case design

✓ Easy to Use - Drawout Case

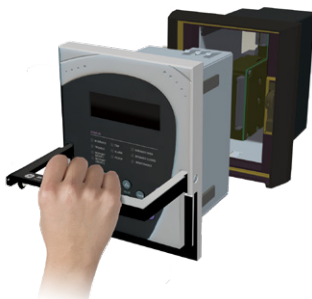

✓ Diagnostic Alarms

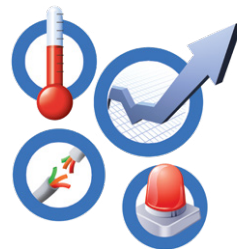

Drawout case design

Enhanced Diagnostics

Preventative Maintenance

The 345 allows users to track relay exposure to extreme environmental conditions by monitoring and alarming at high ambient temperatures. This data allows proactive scheduling of regular maintenance work and upgrade activities. The diagnostics data enables the user to understand degradation of electronics due to extreme conditions.

Switchgear Diagnostics

Trip/Close Circuit Monitoring provides constant monitoring of the health the control circuit. Breaker Health feature provides valuable information about the breaker like tripping, closing and the spring charging time or trip counter, incomplete charging which is of big assistance for proactive maintenance.

Cost Effective

Robust Design and Reduced Life Cycle Cost

The 345 is subjected to Accelerated Life Testing (ALT) to validate accurate relay function under specified normal conditions. The device is further tested for durability through Highly Accelerated Life Testing (HALT) where it undergoes extreme operating conditions.

The robust 345 design along with drawout construction ensures long term operation and reduces the total installation, maintenance and life cycle cost of the protection system, thereby reducing downtime and associated costs.

Fit-for-Purpose Options

Several options for protection, control and communications are provided to match basic to high end application requirements.

The variety of order code selections satisfies the need for various applications from single function Current or Voltage protection to multi-function including Power and Directional elements.

Protection & Control

The 345 transformer protection system is designed to protect and control small to medium size power transformers. Flexible and powerful, the 345 provides advanced transformer protection, control and monitoring in one

economical drawout design. The 345 contains a full range of self-contained protection and control elements as detailed in the Functional Block Diagram and in the Features table.

The 345 can be even used for dual feeder protection.

Percent Differential Protection (87T)

The Percent Differential protection is based on a proven algorithm that provides good sensitivity on detecting internal faults and better stability during through-fault conditions. The protection is characterized with the following key elements:

- Configurable dual slope, dual breakpoint differential/restraint characteristic
- Inrush inhibiting
- Overexcitation inhibits
- Unique Dual Slope-Dual Breakpoint differential and Restraint characteristic

This characteristic defines the area of percent differential protection operation versus no-operation, constructed through the setting

of the minimum pickup differential current, the settings of slope 1 and slope 2 connected by a cubic spline curve, as well as the settings of breakpoint 1 and breakpoint 2. The “cubic spline” curve characteristics enables the relay to perform accurately for restraint current in range between the two slope breakpoints.

The maximum winding current is used as a restraining signal for better through fault stability under CT saturation conditions.

Inrush Inhibit

The 2nd harmonic inrush inhibit function is selectable in order to cover energization of different types of transformers, and can be set to per-phase, 1-out-of-3, 2-out-of-3 or average mode.

Overexcitation inhibit

An increase in transformer voltage, or decrease in system frequency may result in transformer overexcitation condition. In some cases the transformer overexcitation may result in

Functional Block Diagram

ANSI® Device Numbers & Functions

ANSI CODE	61850 LOGICAL NODE	DESCRIPTION
49	PTTR	Thermal Overload
49T	rtdGGIO6	Temperature Monitoring
50/87	insPDIF	Instantaneous Differential
50_2	ngseqPIOC	Negative Sequence Instantaneous Overcurrent
50BF	RBRF	Breaker Failure
50G/SG	gndPIOC/hsePIOC	Ground/Sensitive Ground Instantaneous Overcurrent
50N	ndPIOC	Neutral Instantaneous Overcurrent
50P	phsPIOC	Phase Instantaneous Overcurrent
51_2	ngseqPTOC	Negative Sequence Timed Overcurrent
51G/SG	gndPTOC/hsePTOC	Ground/Sensitive Ground Timed Overcurrent
51N	ndPTOC	Neutral Timed Overcurrent
51P	phsPTOC	Phase Timed Overcurrent
86	-	Lockout
87G (RGF)	rgfPDIF	Restricted Ground Fault
87T	pcntPDIF	Percent Differential

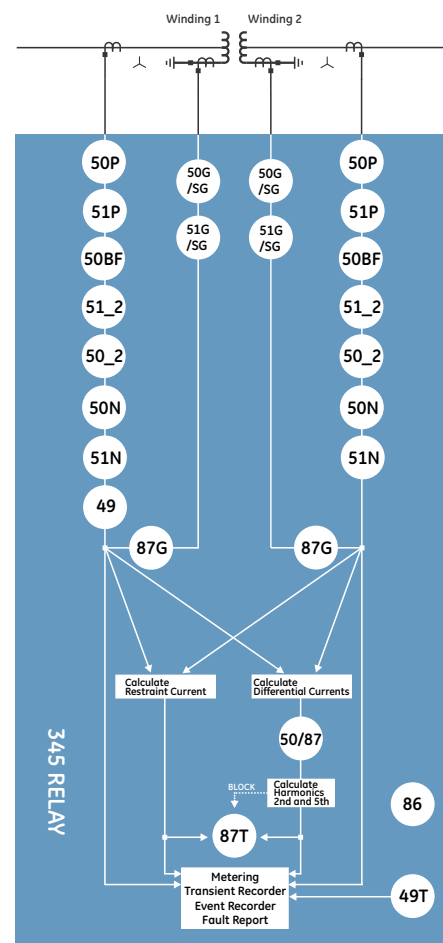

undesirable operation of the percent differential element. Fifth harmonic inhibiting is integrated into the percent differential element to cater such overexcitation conditions.

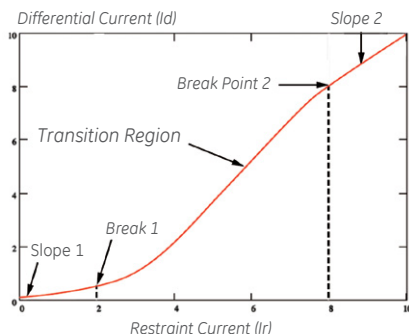

The settings for the dual-slope, dual-breakpoint characteristic provides higher flexibility for shaping up the characteristic and achieve better sensitivity and security.

Unrestrained differential (50/87)

An unrestrained differential element is provided for fast tripping on heavy internal faults to limit further damage to the transformer and minimize the risk to the rest of the system.

Restricted Ground Fault (RGF/87G)

The Restricted Ground Fault (RGF) elements extend the protection coverage to the neutral point of wye-connected windings where fault currents may be below the pickup of the main transformer differential element. The RGF elements use maximum phase winding currents as a restraining signal to provide stability during through fault conditions. Configurable ground current supervision is integrated into the element to add more stability during non-ground out of zone faults with CT saturation, resulting in excessive neutral current, that may be enough to cause RGF operation.

Thermal Overload and Temperature Monitoring (49/49T)

The 345 relay provides basic thermal protection based on winding heating and cooling constants. The protection monitors the winding loading, and is settable to produce alarm or trip, based on the selected overloading criteria.

An optional CANBUS-based RMIO module can be installed on the 345, which can monitor the temperature of up to 12 RTDs.

Overcurrent Elements (50P/N/G/SG/_2, 51P/N/G/SG/_2)

The 345 relay provides phase, neutral, ground and negative sequence over-current functions that are configurable with respect to either

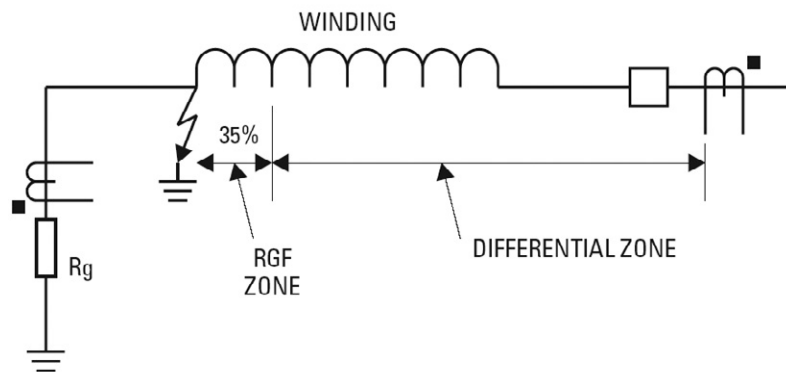

Faults close to the neutral point of a wye-connected winding do not generate adequate fault current for differential element to pick up. Restricted Ground Fault protection provides sensitive ground fault detection for low-magnitude fault currents.

winding currents. They can run in parallel with the main differential protection, and can be set to provide either primary or backup transformer protection for all types of transformer faults.

When ordered with sensitive ground CTs, the 345 relay can be set to provide 10 times more sensitivity on detection of ground fault currents through the transformer winding neutrals grounded via current limiting resistor.

Inputs/Outputs

The 345 features the following inputs and outputs for monitoring and control of typical transformer applications:

- 10 contact Inputs with programmable thresholds
- 2 Form A outputs for breaker trip and close with coil monitoring and 5 Form C output relays

Automation and Integration

Logic Elements

The 345 relay has sixteen Logic Elements available for the user to build simple logic using the state of any programmed contact, virtual, or remote input, or the output operand of a protection or control element.

Use the logic element feature to assign up to eight triggering inputs in an "AND/OR/NOR/NAND/XOR/XNOR" gate for the logic element operation, and up to four blocking inputs in an "AND/OR/NOR/NAND/XOR/XNOR" gate for defining the block signal. Trigger and block sources are grouped for ease of use. Pickup and dropout timers are available for delaying the operation and reset.

Virtual Inputs

Virtual inputs allow communication devices the ability to write digital commands to the 345 relay. These commands can include open/close the breaker, changing setting groups, or blocking any of the protection elements.

IEC61850

The 345 supports IEC 61850 which allows for digital communications to DCS, SCADA and higher level control systems. In addition, the 345 also supports IEC 61850 GOOSE communication, providing a means of sharing digital point state information between several 345 relays or other IEC 61850 compliant IEDs.

- Eliminates the need for hardwiring contact inputs to contact outputs via communication messaging.
- Handles information exchange between devices as fast as 8 ms, depending on the architecture.
- Enables sequence coordination with upstream and downstream devices.
- If a Breaker Open operation malfunctions, GOOSE messaging sends a signal to the upstream breaker to trip and clear the fault.

Metering, Monitoring and Diagnostics

Event Recording

Events consist of a broad range of change of state occurrences, including pickups, trips, contact operations, alarms and self test status.

The 345 relay stores up to 256 events, time tagged to the nearest millisecond. This provides the information required to determine sequence

of events, facilitating the diagnosis of relay operation. Event types are individually maskable in order to avoid generating undesired events, and include the metered values at the moment of the event.

Oscillography / Transient Fault Recorder

The 345 captures current waveforms and digital channels at 32 samples per cycle. The oscillography record captures 8 individual analog channels allowing for detailed analysis. The oscillography is triggered either by internal signals or an external contact.

Trip/Close Coil Monitoring

The 345 can be used to monitor the integrity of both the breaker trip and closing coils and circuits. The supervision inputs monitor both the auxiliary voltage levels, while the outputs monitor the continuity of the trip and/or closing circuits, by applying a small current through the circuits.

Test Mode

The Test Mode for 3 Series relays consists of testing front panel LEDs, Inputs and Outputs. It can be used to test the SCADA system as well.

Advanced Device Health Diagnostics

The 345 performs comprehensive device health diagnostic tests during startup and continuously at runtime to test major functions and critical hardware. These diagnostic tests monitor for conditions that could impact system reliability.

Device status is communicated via SCADA communications and the front panel display. This continuous monitoring and early detection of possible issues helps improve system availability by employing predictive maintenance.

Temperature Monitoring

The 345 continually monitors ambient temperature around the relay and alarms when the device is exposed to extreme temperatures and undesirable conditions such as air-conditioning unit or station heater failures.

The EnerVista Viewpoint maintenance tool allows users to review and analyze the time period a 345 relay is exposed to certain temperature ranges.

IRIG-B

The 345 captures current and voltage waveforms and digital channels at up to 32 samples per cycle (user-selectable). Multiple records can be stored in the relay at any given time with a maximum length of 192 cycles. Oscillography is triggered either by internal signals or an external contact.

Metering

The 345 continuously measures and computes the following AC signals indicating the health of the protected transformer:

- Phase winding currents
- Winding ground current

- Winding neutral current
- Winding negative sequence current
- Differential and restraint currents per-phase
- Winding ground differential current
- Percent 2nd and 5th harmonics differential currents per phase
- Percent thermal capacity per-phase
- Current demand

The states of all digital inputs/outputs are provided through the actual values either from the summary pages or individually. This includes:

States of contact inputs

- States of virtual inputs
- States of remote inputs
- States of relay outputs
- States of logic elements

Security

Password Control

The password system has been designed to facilitate a hierarchy for centralized management. With the implementation of the Password Security feature in the 345 relay, extra measures have been taken to ensure unauthorized changes are not made to the relay. When password security is enabled, changing of setpoints or issuing of commands will require passwords to be entered. Separate passwords are supported for remote and local operators, and separate access levels support changing of setpoints or sending commands.

Logic Designer

SETTING	PARAMETER
LOGIC ELEMENT 1	
Name	Alarm #1
Function	Disabled
Asserted	On
Number of Triggers	8
Trigger Source 1	Contact IN 1 On
Trigger Source 2	Contact IN 2 On
Trigger Source 3	LE 1 Trip PKP
Trigger Source 4	LE 2 Trip OP
Trigger Source 5	Virtual IN 1 On
Trigger Source 6	Virtual IN 2 On
Trigger Source 7	Remote IN 10 Off
Trigger Source 8	Remote IN 21 Off
Trigger Logic	OR
Pickup Time Delay	5 ms
Dropout Time Delay	15 ms
Relays	Relay : 4
Number of Blocks	4
Block 1	Virtual IN 1 On
Block 2	Virtual IN 2 On
Block 3	Remote IN 1 On
Block 4	Remote IN 7 Off
Block Logic	XOR

Sixteen logic elements available for applications such as manual control, interlocking and peer to peer tripping.

Advanced Communications

The 345 utilizes the most advanced communication technologies today making it the easiest and most flexible transformer protection relay to use and integrate into new and existing infrastructures. Multiple communication ports and protocols allow control and easy access to information from the 345.

The 345 supports the most popular industry standard protocols enabling easy, direct integration into electrical SCADA and HMI systems. Modbus RTU is provided as standard with a RS485 networking port.

The following optional protocols are available:

- IEC 61850
- Modbus TCP/IP
- IEC 61850 GOOSE
- IEC 60870-5-104
- DNP 3.0
- IEC 60870-5-103
- Modbus RTU

These protocols make it easy to connect to a Utility or Industrial automation system, eliminating the need for external protocol converter devices.

Energista Software

The Energista suite is an industry leading set of software programs that simplifies every aspect of using the 345 relay. The Energista suite provides all the tools to monitor the status of the protected asset, maintain the relay, and integrate the information measured into DCS or SCADA monitoring systems. Convenient COMTRADE and sequence of event viewers are an integral part of the 345 set up software and are included to ensure proper protection and system operation.

Simplified Transformer Setting

Included with every 345 Transformer Protection System is the Multilin Simplified Transformer Setup. The Simplified Transformer Setup provides users with a quick and easy method to setup and start the transformer and process in applications that require fast commissioning.

The Simplified Transformer Setup will generate a complete 345 setting file based on the transformer nameplate and system information entered by the user. Once all the information is entered, the Simplified Transformer Setup will generate the settings file, as well as provide the documentation indicating which settings were enabled, along with an explanation of the specific parameters entered. The Simplified Transformer Setup will provide a detailed setting file in PDF format that can be saved or printed for future reference.

Launchpad

Energista Launchpad is a powerful software package that provides users with all of the set up and support tools needed for configuring and maintaining GE products. The setup software within Launchpad allows configuring devices in real time by communicating using serial, Ethernet or modem connections, or offline by creating setting files to be sent to devices at a later time. Included in Launchpad is a document archiving and management system that ensures critical documentation is up-to-date and available when needed. Documents made available include:

SECURITY/CHANGE HISTORY REPORT

Generated at: September 15 2010 16:56:05

Device Summary									
Device Name:	345								
Device Type:	SR 345								
Order Code:	345-EP55SHSMNN2EDN								
Firmware Version:	1.30								
Serial Number:	BL0A09000565								
Communication:	COM 3, 115200								



Setting Changes History									
Session#	Date of Change	Method of Change	# Of Changes	Password Entered	Changes by Whom IP /Mac	Event Type	Filename	Status	Firm. Version
1	09/15/2010 06:23:20 PM	USB	0	Yes	0:0:0:0	Setpoint File		Relay Ready	130
2	09/15/2010 06:24:52 PM	USB	14	Yes	3:13:81:141	Setpoint Change	345_130.sr3 : C:	Relay Ready	130

Setting Changes Detail History					
Session#	Date Of Change	Old Value	New Value	Data Item	Modbus Address
2	09/15/2010 06:24:52 PM	50	5	W1 Sensitive Ground CT Primary	0Xe49
2	09/15/2010 06:24:52 PM	50	5	W2 Sensitive Ground CT Primary	0Xe4a
2	09/15/2010 06:24:52 PM	5	5000	W1 Phase CT Primary	0Xe4b
2	09/15/2010 06:24:52 PM	5	5000	W2 Phase CT Primary	0Xe4d
2	09/15/2010 06:24:58 PM	0	1	Supply Frequency	0X11b
2	09/15/2010 06:25:13 PM	0	1	Phase Compensation	0X58e
2	09/15/2010 06:25:18 PM	0	1	Winding 2 Grounding	0X594
2	09/15/2010 06:29:39 PM	0	69	Breaker Connected	0X56b
2	09/15/2010 06:29:39 PM	0	64	Breaker 52a Contact	0X56c
2	09/15/2010 06:29:39 PM	0	65	Breaker 52b Contact	0X56d
2	09/15/2010 06:29:49 PM	0	70	Breaker 2 Connected	0X585



Trace any setting changes with security audit trail

- Manuals
- Application Notes
- Guideform Specifications
- Brochures
- Wiring Diagrams
- FAQs
- Service Bulletins

Viewpoint Monitoring

Viewpoint Monitoring is a simple to use and full featured monitoring and data recording software package for small systems. Viewpoint monitoring provides a complete HMI package with the following functionality:

- Plug and play device monitoring
- System single line monitoring and control
- Annunciator alarm screens
- Trending reports
- Automatic event retrieval
- Automatic waveform retrieval

Viewpoint Maintenance

Viewpoint Maintenance provides tools that will increase the security of the 345 Transformer Protection System. Viewpoint Maintenance will create reports on the operating status of the relay, and simplify the steps to troubleshoot protected transformers.

The tools available in Viewpoint Maintenance include:

- Settings Security Audit Trail
- Device Health Report
- Comprehensive Fault Diagnostics

EnerVista Integrator

EnerVista Integrator is a toolkit that allows seamless integration of Multilin devices into new or existing automation systems.

Included in the EnerVista Integrator is:

- OPC/DDE Server
- Multilin Devices
- Automatic Event Retrieval
- Automatic Waveform Retrieval

Power System Troubleshooting

Analyze power system disturbances with transient fault recorder and event records

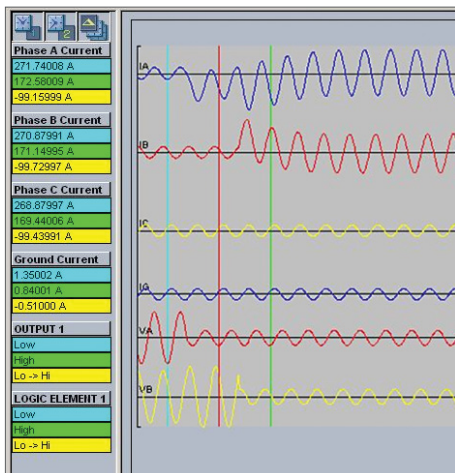

Event Records // Quick Connect: Quick Connect Device: Actual Values: A3 Records

Event	Select	Date	Time	Cause of Event
76	<input type="checkbox"/>	03/4/2009	15:02:55.561	Reset
75	<input checked="" type="checkbox"/>	03/4/2009	15:02:12.908	Breaker Status Open
74	<input type="checkbox"/>	03/4/2009	15:02:12.901	Contact Input 1 Off
73	<input type="checkbox"/>	03/4/2009	15:02:11.775	Phase C TOC Trip Operate
72	<input type="checkbox"/>	03/4/2009	15:02:11.775	Phase A TOC Trip Operate
71	<input type="checkbox"/>	03/4/2009	15:02:11.759	Output Relay 3
70	<input type="checkbox"/>	03/4/2009	15:02:11.759	Trip Coil
69	<input type="checkbox"/>	03/4/2009	15:02:11.759	Trip Coil Pickup
68	<input type="checkbox"/>	03/4/2009	15:02:11.758	Phase TOC Trip Operate
67	<input type="checkbox"/>	03/4/2009	15:02:11.758	Phase B TOC Trip Operate

All None Select Events 75

Event Parameter	Value
Event Ia	0° Lag
Event Ib	120° Lag
Event Ic	240° Lag
Event Ig	0° Lag
Event Frequency	59.99 Hz
Therm Cap PH A	0.0%
Therm Cap PH B	0.0%
Therm Cap PH C	0.0%

Save Restore Default

PARAMETER	VALUE
Fault Report Order Code	350-LPSGSHMCVSEDN
Fault Report Feeder Name	Feeder Name
Fault Report Firmware Version	2.20
Fault Report Date	06/30/2016
Fault Report Time	07:35:17
Fault Report Fault Type	Phase IOC1 Trip OP
Active Setpoint Group	Group 1
Fault Report Ia	40.0 A
Fault Report Ia Angle	358 °
Fault Report Ib	40.0 A
Fault Report Ib Angle	117 °
Fault Report Ic	39.3 A
Fault Report Ic Angle	237 °
Fault Report Ig	0.0 A
Fault Report Ig Angle	0 °
Fault Report In	0.0 A
Fault Report In Angle	0 °
Fault Report Va	30 V
Fault Report Va Angle	0 °
Fault Report Vb	30 V
Fault Report Vb Angle	120 °
Fault Report Vc	30 V
Fault Report Vc Angle	240 °
Fault Report Vab	52 V
Fault Report Vab Angle	330 °

User Interface



Twelve LEDs (8 optional programmable LEDs)

IN SERVICE: This indicator will be on continuously lit if the relay is functioning normally and no major self-test errors have been detected.

TROUBLE: Trouble indicator LED will be AMBER if there is a problem with the relay or the relay is not configured.

TRIP: Indicates that the relay has tripped the transformer offline based on predefined programmed conditions.

ALARM: Indicates that the transformer is currently operating in an alarm condition and may proceed to a trip condition if not addressed.

MAINTENANCE: Environmental alarms such as ambient temperature alarm or coil monitor alarms.

The display messages are organized into Main Menus, Pages, and Sub-pages.

There are four main menus labeled Actual Values, Quick Setup, Setpoints, and Maintenance. Pressing the MENU key followed by the MESSAGE key scrolls through the four Main Menu Headers.

The ten button keypad allows users easy access to relay configuration, information and control commands.

INSTALLATION OPTIONS: Drawout and non-drawout options available

Dimensions

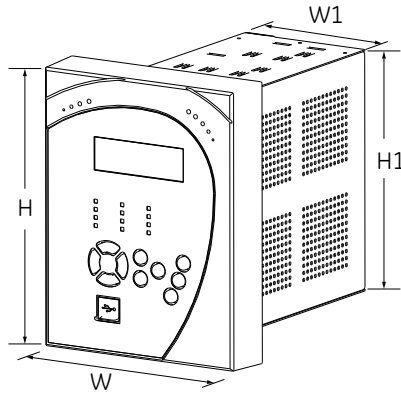
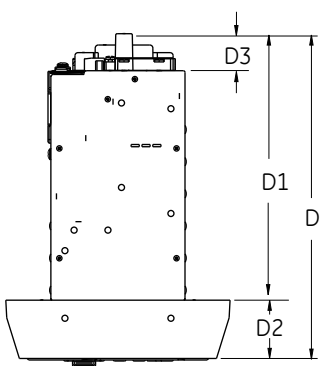

	DRAWOUT		NON-DRAWOUT	
	in	mm	in	mm
H	7.93	201.5	7.98	202.7
W	6.62	168.2	6.23	158.2
D	9.62	244.2	9.35	237.5
W1	3.96	100.6	3.96	100.6
D1	7.89	200.4	7.88	200.2
D2	1.73	43.8	1.47	37.3
D3	1.087	27.6	0.755	19.17
H1	6.82	173.2	6.82	173.2

Mounting

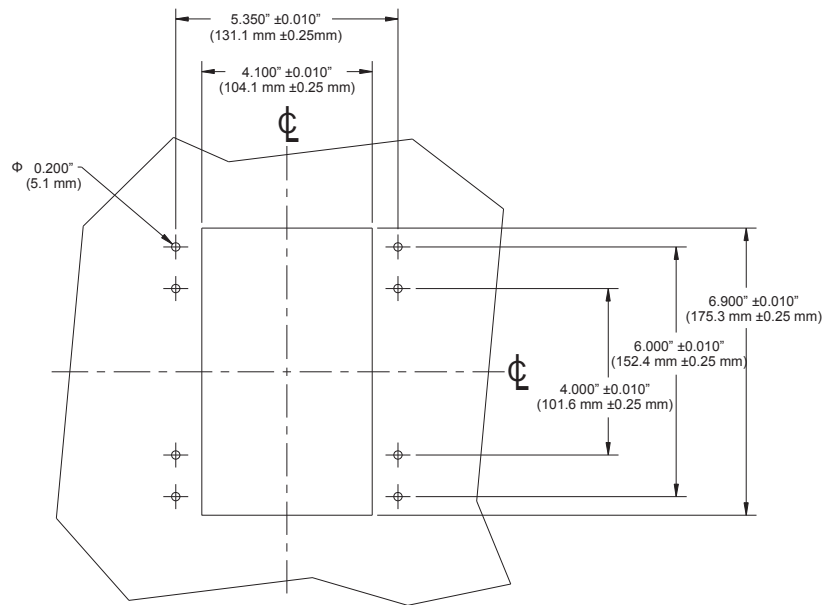

3 Series Depth Reducing Collar

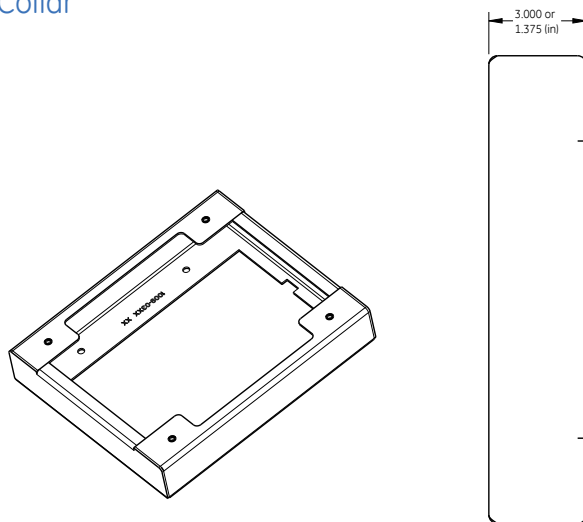

Typical Wiring Diagram

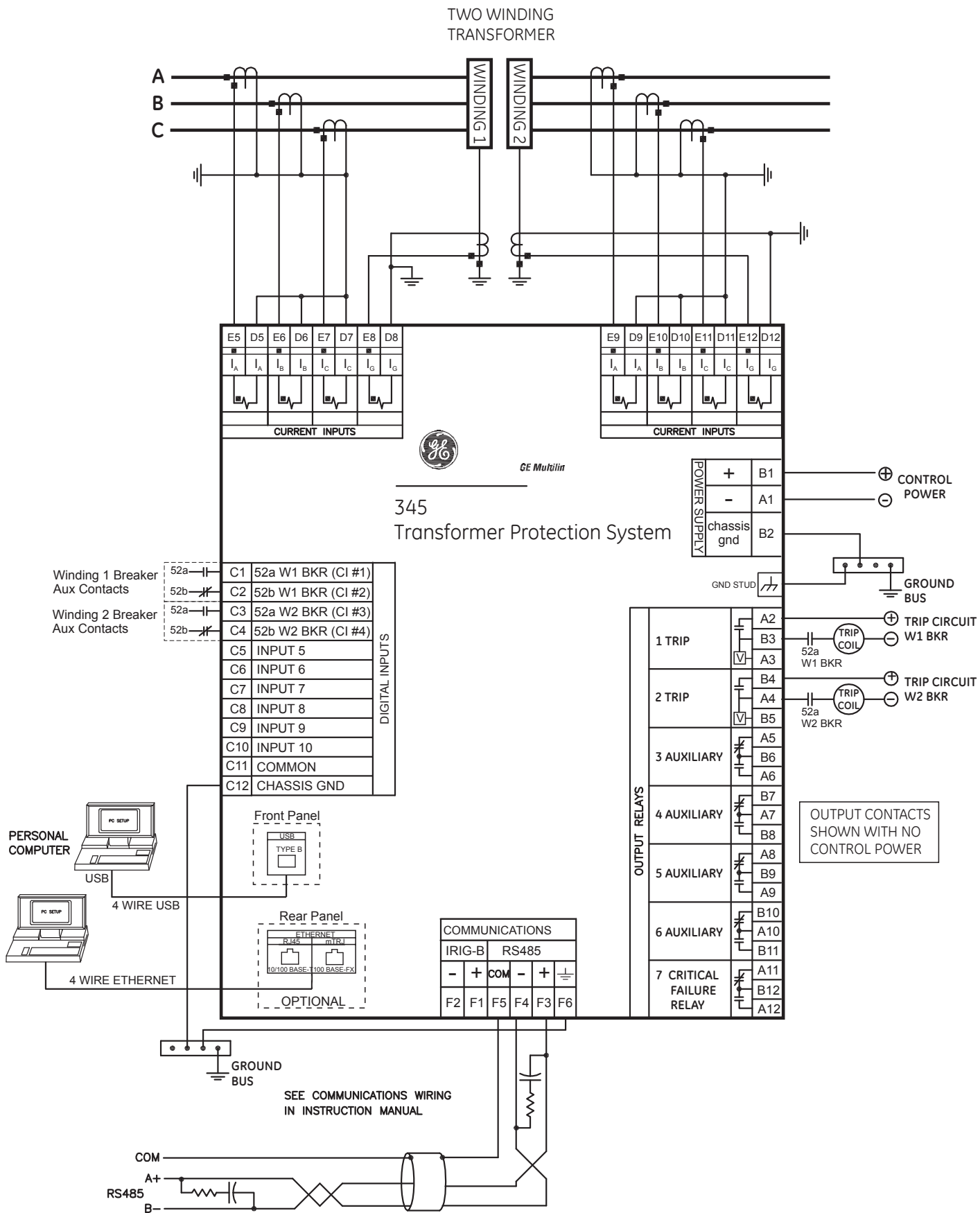

Technical Specifications

PASSWORD SECURITY		RESTRICTED GROUND FAULT (87G)		LOGIC ELEMENTS	
Master Reset	8 to 10 alpha-numeric characters	Number of Elements:	2	Number of logic elements:	16
Settings Password:	3 to 10 alpha-numeric characters for local or remote access	Pickup Level:	0.02 to 20.00 xCT in steps of 0.01 0.002 to 2.000 xCT (with sensitive CTs)	Trigger source inputs per element:	2 to 8
Control Password:	3 to 10 alpha-numeric characters for local or remote access	GND Supervision Level:	0.02 to 20.00 xCT in steps of 0.01 0.002 to 2.000 xCT (with sensitive CTs)	Block inputs per element:	2 to 4
PHASE/NEUTRAL/GROUND/NEGATIVE SEQUENCE TIMED OVERCURRENT (51P/51N/51G/51_2)		Dropout Level:	97% of Pickup	Supported operations:	AND, OR, NOR, NAND, XOR, XNOR, Pickup / Dropout timers
Pickup Level:	0.05 to 20.00 x CT in steps of 0.01 x CT	Slope Range:	0 to 100% in steps of 1	Pickup timer:	0 to 60000 ms in steps of 1 ms
Dropout Level:	97% of Pickup @ I > 0.1 x CT pickup - 0.02 x CT @ I < 0.1 x CT	Pickup Delay:	0.00 to 600.0 s in steps of 0.01	Dropout timer:	0 to 60000 ms in steps of 1 ms
Curve Shape:	ANSI Extremely/Very/Moderately/Normally Inverse Definite Time (1 s base curve) IEC Curve A/B/C/Short IAC Extremely/Very/Inverse/Short	Operate Time:	< 30 ms @ 0 ms time delay	BREAKER FAILURE (50BF)	
Curve Multiplier:	0.05 to 20.00 in steps of 0.01	Level Accuracy:	per current inputs	Pickup Level:	0.05 to 20.00 x CT in steps of 0.01 x CT
Reset Time:	Instantaneous, Linear	PHASE & GROUND CURRENT INPUTS		Dropout Level:	97 to 98% of pickup
Time Delay:	±3% of expected inverse time or 1 cycle, whichever is greater, from pickup to operate	CT Primary:	1 to 6000 A	Timer 1 Delay:	0.03 to 1.00 s in steps of 0.01 s
Accuracy:	whichever is greater, from pickup to operate per CT input	Range:	0.02 to 20 x CT	Timer 2 Delay:	0.00 to 1.00 s in steps of 0.01 s
SENSITIVE GROUND TIMED OVERCURRENT (51SG)		Input type:	1 A or 5 A (must be specified with order P1G1 or P5G5) Configurable 1 A or 5 A (must be specified with order P0G0)	Time Delay Accuracy:	0 to 1 cycle (Timer 1, Timer 2)
Pickup Level:	0.005 to 3.000 x CT in steps of 0.001 x CT	Nominal frequency:	50/60 Hz	Level Accuracy:	per CT input
Dropout Level:	97% of Pickup @ I > 0.1 x CT pickup - 0.002 x CT @ I < 0.1 x CT	Burden:	<0.1 VA at rated load	Reset Time:	<14 ms typical at 2 x pickup at 60 Hz <16 ms typical at 2 x pickup at 50 Hz
Curve Shape:	ANSI Extremely/Very/Moderately/Normally Inverse Definite Time IEC Curve A/B/C/Short IAC Extremely/Very/Inverse/Short	Accuracy:	±3% of reading from 0.1 to 20 x CT ± 10 mA or ±20% of reading from 0.02 to 0.19 x CT	LOCKOUT	
Curve Multiplier:	0.05 to 50.00 in steps of 0.1	CT withstand:	1 second at 100 A (1 A option) 1 second at 400 A (5 A or universal CT option) 2 seconds at 40 x rated current continuous at 3 x rated current	Function:	Latch Trip command to Relay 1 TRIP Block Close to Relay 2 CLOSE
Reset Time:	Instantaneous, Linear	SENSITIVE GROUND CURRENT INPUT		Operation:	Any protection element
Time Delay:	±3% of expected inverse time or 1 cycle, whichever is greater, from pickup to operate	CT Primary:	1 to 600 A	AMBIENT TEMPERATURE	
Accuracy:	whichever is greater, from pickup to operate per CT input	Range:	0.002 to 3 x CT	High Temperature:	20°C to 80°C in steps of 1°C
PHASE/NEUTRAL/GROUND/NEGATIVE SEQUENCE INSTANTANEOUS OVERCURRENT (50P/50N/50G/50_2)		Input type:	1 A or 5 A (must be specified with order P1S1 or P5S5) Configurable 1 A or 5 A (must be specified with order P0S0)	Pickup:	Low Temperature -40°C to 20°C in steps of 1°C
Pickup Level:	0.05 to 20.00 x CT in steps of 0.01 x CT	Nominal frequency:	50/60 Hz	Time Delay:	1 to 60 min in steps of 1 min
Dropout Level:	97% of Pickup @ I > 0.1 x CT Pickup - 0.02 x CT @ I < 0.1 x CT	Burden:	<0.1 VA at rated load	Temperature:	Configurable 90 to 98% of pickup
Time delay:	0.00 to 300.00 sec in steps of 0.01	Accuracy:	±3% of reading from 0.02 to 20 x CT ± 10 mA or ±20% of reading from 0.002 to 0.019 x CT	Dropout:	Temperature ±10°C
Operate Time:	<30 ms @ 60Hz (I > 2.0 x PKP, No time delay) <35 ms @ 50Hz (I > 2.0 x PKP, No time delay)	CT withstand:	1 second at 100 A (1 A option) 1 second at 400 A (5 A or universal CT option) 2 seconds at 40 x rated current continuous at 3 x rated current	Accuracy:	±1 second
Time Delay:	0 to 1 cycle (time delay selected)	TRANSIENT RECORDER		Timing Accuracy:	±1 second
Accuracy:	per CT input	Buffer size:	3 s	BREAKER HEALTH	
Level Accuracy:	per CT input	No. of buffers:	1, 3, 6	Timer:	± 3% of delay setting or ± 1 cycle (whichever is greater) from pickup to operate
TRANSFORMER PERCENT DIFFERENTIAL PROTECTION (87T)		No. of channels:	14	Accuracy:	greater) from pickup to operate
Differential/Restraint Characteristic:	Dual Slope, Dual Breakpoint	Sampling rate:	4, 8, 16, or 32 samples per cycle	DEMAND	
Minimum Pickup Level:	0.05 to 1.00 x CT in steps of 0.01	Triggers:	Manual Command Contact Input Virtual Input Logic Element Element Pickup/Trip/Dropout/Alarm	Measured Values:	Phase A/B/C present and maximum current
Slope 1 Range:	15 to 100% in steps of 1%	Data:	AC input channels Contact input state Contact output state Virtual input state Logic element state	Measurement Type:	Thermal Exponential, 90% response time (programmed): 5, 10, 15, 20, 30 minutes
Slope 2 Range:	50 to 100% in steps of 1%	Data storage:	RAM - battery backed-up	Block Interval / Rolling Demand, time interval (programmed):	5, 10, 15, 20, 30 minutes
Kneepoint 1:	0.50 to 4.00 x CT in steps of 0.01	FAULT RECORDER		Current Pickup Level:	10 to 10000 in steps of 1 A
Kneepoint 2:	1.00 to 10.00 x CT in steps of 0.01	Number of records:	1	Dropout Level:	96-98% of Pickup level
2 nd Harmonic Inhibit Level:	1.0 to 40.0% in steps of 0.1%	Content:	Date and Time, first cause of fault, phases, Currents: Ia, Ib, Ic, Ig/Isg, In - magnitudes and angles	Level Accuracy:	± 2%
2 nd Harmonic Inhibit Mode:	Per-phase, 2-out-of-three, Average	EVENT RECORDER		CONTACT INPUTS	
5 th Harmonic Inhibit Level:	1.0 to 40.0% in steps of 0.1%	Number of events:	256	Inputs:	10
Dropout Level:	95% of Pickup	Header:	relay name, order code, firmware revision	Selectable thresholds:	17, 33, 84, 166 VDC
Operate Time:	< 20 ms (no harmonics inhibits selected) < 30 ms (harmonics inhibits selected)	Content:	event number, date of event, cause of event, per-phase current, ground current, sensitive ground current, neutral current, ground differential current, negative sequence current, restraint current, per-phase differential current, per-phase differential second harmonic current, thermal capacity	Recognition time:	1/2 cycle
Level Accuracy:	per current inputs	Data Storage:	RAM - battery backed up; retained for 3 days	Tolerance:	+/- 10%
TRANSFORMER THERMAL PROTECTION (49)		CLOCK		Debounce time:	1 to 64 ms, selectable, in steps of 1 ms
Current:	RMS current - max (Ia, Ib, Ic)	Setup:	Date and Time (Daylight Savings Time)	Maximum input voltage & continuous current draw:	300 VDC, 2 mA, connected to Class 2 source
Pickup Accuracy:	per current inputs	IRIG-B:	Auto-detect (DC shift or Amplitude Modulated) Amplitude modulated: 1 to 10 V pk-pk DC shift: 1 to 10 V DC Input impedance: 40 kOhm ± 10% Accuracy with IRIG-B: ± 1 ms Accuracy without IRIG-B: ± 1 min / month	Type:	opto-isolated inputs
Timing Accuracy:	±3% of expected time, or 30 ms (whichever is greater) @ I > 1.5 x PKP	FORM-A RELAYS		External switch:	wet contact
SENSITIVE GROUND INSTANTANEOUS OVERCURRENT (50SG)		FORM-A VOLTAGE MONITOR		RTD (49T)	
Pickup Level (Gnd IOC):	0.005 to 3.000 x CT in steps of 0.001 x CT	Applicable voltage:	20 to 250 VDC	Pickup:	1 to 250°C in steps of 1°C
Dropout Level:	97% of Pickup @ I > 0.1 x CT Pickup - 0.002 x CT @ I < 0.1 x CT	Trickle current:	1 to 2.5 mA	Pickup Hysteresis:	2°C
Time delay:	0.00 to 300.00 sec in steps of 0.01	TRANSFORMER INSTANTANEOUS DIFFERENTIAL PROTECTION (50/87)		Time Delay:	3 sec
Operate Time:	<30 ms @ 60Hz (I > 2.0 x PKP, No time delay) <35 ms @ 50Hz (I > 2.0 x PKP, No time delay)	Pickup Level:	3.00 to 20.00 xCT in steps of 0.01 xCT	Elements:	Trip and Alarm
Time Delay:	0 to 1 cycle (time delay selected)	Dropout Level:	97 to 98% of Pickup		
Accuracy:	per CT input	Operate Time:	<30 ms		
Level Accuracy:	per CT input	Level Accuracy:	per current inputs		

Technical Specifications

RTD TROUBLE ALARM(49T)	
RTD Trouble Alarm	<-50°C or >250°C
FORM-C RELAYS	
Configuration:	5 (five) electromechanical
Contact material:	silver-alloy
Operate time:	<8 ms
Continuous current:	10 A
Make and carry for 0.2s:	30 A per ANSI C37.90
Break [DC inductive, L/R=40 ms]:	24 V / 1 A 48 V / 0.5 A 125 V / 0.3 A 250 V / 0.2 A
Break [DC resistive]:	24 V / 10 A 48 V / 6 A 125 V / 0.5 A 250 V / 0.3 A
Break (AC inductive):	720 VA @ 250 VAC Pilot duty A300
Break (AC resistive):	250 VAC / 10 A
TRIP SEAL-IN	
Relay 1 trip seal-in:	0.00 to 9.99 s in steps of 0.01
Relay 2 trip seal-in:	0.00 to 9.99 s in steps of 0.01
HIGH-RANGE POWER SUPPLY	
Nominal:	120 to 240 VAC 125 to 250 VDC
Range:	60 to 300 VAC (50 and 60 Hz) 84 to 250 VDC
Ride-through time:	35 ms
LOW-RANGE POWER SUPPLY	
Nominal:	24 to 48 VDC
Range:	20 to 60 VDC
ALL POWER SUPPLY RANGES	
Voltage withstand:	2 x highest nominal voltage for 10 ms
Power consumption:	15 W nominal, 20 W maximum
Fuse rating:	20 VA nominal, 28 VA maximum 5A fuse; time lag, slow blow, 350V 4.5 O.D. X 14.5mm
ETHERNET (COPPER)	
Modes:	10/100 MB (auto-detect)
Connector:	RJ-45
Protocol:	Modbus TCP, DNP3.0, IEC 60870-5-104, IEC 61850 GOOSE, IEC 61850
ETHERNET (FIBER)	
Fiber type:	100 MB Multi-mode
Wavelength:	1300 nm
Connector:	MTRJ
Transmit power:	-20 dBm
Receiver sensitivity:	-31 dBm
Power budget:	9 dB
Maximum input power:	-11.8 dBm
Typical distance:	2 km (1.25 miles)
Duplex:	half/full
Protocol:	Modbus TCP, DNP3.0, IEC 60870-5-104, IEC 61850 GOOSE, IEC 61850
SERIAL	
RS485 port:	Opto-coupled
Baud rates:	up to 115 kbps
Response time:	1 ms typical
Parity:	None, Odd, Even
Protocol:	Modbus RTU, DNP 3.0, IEC 60870-5-103
Maximum distance:	1200 m (4000 ft)
Isolation:	2 kV
USB	
Standard specification:	Compliant with USB 2.0
Connector:	115 kbps

TEST	REFERENCE STADARD	TEST LEVEL
Dielectric voltage withstand		
high voltage power supply*	60255-27	2200 VAC for one second
low voltage power supply*	60255-27	550 VAC for one second
Impulse voltage withstand	EN60255-27	5kV
Damped Oscillatory	IEC 60255-26 / IEC61000-4-18	2.5kV CM, 1 kV DM
Electrostatic Discharge	IEC 60255-26 / IEC 61000-4-2	15 kV / 8 kV
RF immunity	IEC 60255-26 / IEC 61000-4-3	80 MHz- 1 GHz, 1.4 Ghz-2.7Ghz, 10 V/m
Fast Transient Disturbance	IEC 60255-26 / IEC 61000-4-4	2 or 4 kV
Surge Immunity	IEC 60255-26 / IEC 61000-4-5	0.5, 1 & 2 kV
Conducted RF Immunity	IEC 60255-26 / IEC 61000-4-6	150 kHz-80 MHz, 26-68 MHz, 10V/m
Voltage interruption & Ripple DC	IEC 60255-26 / IEC 61000-4-11	15% ripple, 200ms interrupts
Radiated & Conducted Emissions	CISPR11 / CISPR22 / IEC 60255-26: Section 7.1.2 & 7.1.3	Class A
Sinusoidal Vibration	IEC 60255-21-1	Class 1
Shock & Bump	IEC 60255-21-2	Class 1
Seismic	IEC 60255-21-3	Class 2
Power magnetic Immunity	IEC 60255-26 / IEC 61000-4-8	1000 A/m, 100 A/m, 30A/m 300 A/m
Voltage Dip & interruption	IEC 60255-26 / IEC 61000-4-11	0, 40, 70, 80% dips, 250/300 cycle interrupts
Power frequency	IEC 60255-26 / IEC 61000-4-16	Level 4
Voltage Ripple	IEC 60255-26 / IEC 61000-4-17	15% ripple
Ingress Protection	IEC 60529	IP54 front, IP10 Back
Environmental (Cold)	IEC 60068-2-1	-40°C 16 hrs
Environmental (Dry heat)	IEC 60068-2-2	85°C 16hrs
Relative Humidity Cyclic	IEC 60068-2-30	6 day variant 2
EFT	IEEE / ANSI C37.90.1	4KV, 2.5Khz
Damped Oscillatory	IEEE / ANSI C37.90.1	2.5KV, 1Mhz
RF Immunity	IEEE / ANSI C37.90.2	35V/m (max field), (80 MHz-1 GHz with 1 KHz sine and 80% AM modulation)
ESD	IEEE / ANSI C37.90.3	8KV CD/ 15KV AD
Safety	UL 508 UL C22.2-14 UL 1053	e83849 NKCR e83849 NKCR7 e83849 NKCR
* Test level is based on basic insulation principle (Power supply I/P terminals tested to Chassis ground).		
CERTIFICATION		
CE:	Applicable council directive according to Low voltage directive 2014/35/EU EMC Directive EMC Directive 2014/30/EU, UL508	
North America:	cULus, UL1053, C22.2 No 14	
EAC:	Machines and Equipment, TR CU 010/2011	
ISO:	Manufactured under a registered quality program ISO9001	
LLOYD's Register	Rules and regulations for classifications of Ships, Marine Applications: ENV2, ENV3	

EAC	
The EAC Technical Regulations (TR) for Machines and Equipment apply to the Customs Union (CU) of the Russian Federation, Belarus, and Kazakhstan	
Country of origin	Spain or Canada; see label on the unit
Date of manufacture	See label on the side of the unit
Declaration of Conformity and/or Certificate of Conformity	Available upon request
OPERATING ENVIRONMENT	
Ambient operating temperature:	-40°C to +60°C [-40°F to +140°F]
Ambient storage / shipping temperature:	-40°C to +85°C [-40°F to +185°F]
Humidity:	Operating up to 95% (non condensing) @ 55C (As per IEC60068-2-30 Variant 2, 6days)
Altitude:	2000m (max)
Pollution degree:	II
Overvoltage category:	III
Ingress Protection:	IP54 Front , IP10 back (IP20 cover is available for drawout version)
Noise:	0 dB
DIMENSIONS	
Size:	Refer to Dimensions section
WEIGHT	
NON-DRAWOUT UNIT	
Weight (net):	2.9 kg (6.4 lbs)
Weight (gross):	4.0 kg (8.6 lbs)
DRAWOUT UNIT	
Weight (net):	3.9 kg (8.6 lbs)
Weight (gross):	5.0 kg (11.0 lbs)

Ordering

Multilin 345	E	**	**	**	E	*	N	N	*	*	*	*	Description
Base Unit	345												Base Unit
User Interface	E												English without programmable LEDs
	L												English with programmable LEDs
Phase Currents ^a		P0											1A or 5A configurable phase current inputs
		P1											1A 3-phase CTs (Winding 1 - 1A, Winding 2 - 1A)
		P5											5A 3-phase CTs (winding 1 - 5A, Winding 2 - 5A)
Ground Currents ^b			G0										1A or 5A configurable ground current input
			G1										1A standard ground CTs (Winding 1 - 1A, Winding 2 - 1A)
			G5										5A standard ground CTs (Winding 1 - 5A, Winding 2 - 5A)
			S0										1A or 5A configurable sensitive ground current input
			S1										1A sensitive ground CTs (Winding 1 - 1A, Winding 2 - 1A)
			S5										5A sensitive ground CTs (Winding 1 - 5A, Winding 2 - 5A)
Power Supply			L										24 to 48 V DC
			H										125 to 250 V DC/120 to 240 V AC
Current Protection ^c					S								Standard: 87T, 87T-50, 51P(1), 51N(1), 51G(1), 50P(1), 50G(1), 50N(1), 49P, 46 (51_2/50_2), 86
					M								Advanced: 87T, 87T-50, 51P(2), 51N(2), 51G(2), 50P(2), 50G(2), 50N(2), 49P, 46 (51_2/50_2), 86, 50BF(2), 87G/RGF(2)
Communications						S	N						Standard :Front USB, Rear RS485 : Modbus RTU, DNP3.0, IEC60870-5-103
						1	E						Standard + Ethernet (Copper & Fiber - MTRJ) MODBUS TCP/IP, DNP3.0, IEC 60870-5-104
						3	E						Standard + Ethernet (Copper & Fiber - MTRJ) MODBUS TCP/IP, DNP3.0, IEC 60870-5-104, IEC 61850
Case Design									D				Protection Relay with drawout design
									N				Protection Relay with non-drawout design
									X				Protection Relay (drawout design) with no chassis
Harsh Environment										N			None
										H			Harsh Environment Conformal Coating

Ordering Notes:

^a Phase current option "P0" and Ground current option "G0" is only available on the non-drawout version (Case Design option "N")

^b Ground current options "G0/G1/G5" and "S0/S1/S5" must match the corresponding "P0/P1/P5" Phase currents. The selected phase and ground CTs apply to both windings.

^c Current protection option "E" has been discontinued.

345	CH	*	*	*	N	N	*	*	*	*	Description
Phase Currents		P1									1 A 3-phase CTs (Winding 1 - 1 A, Winding 2 - 1 A)
		P5									5 A 3-phase CTs (Winding 1 - 5 A, Winding 2 - 5 A)
Ground Currents ^a			G1								1 A standard ground CTs (Winding 1 - 1 A, Winding 2 - 1 A)
			G5								5 A standard ground CTs (Winding 1 - 5 A, Winding 2 - 5 A)
			S1								1 A sensitive ground CTs (Winding 1 - 1 A, Winding 2 - 1 A)
			S5								5 A sensitive ground CTs (Winding 1 - 5 A, Winding 2 - 5 A)
Communications						S	N				Standard: Front USB, Rear RS485: Modbus RTU, DNP3.0, IEC60870-5-103
						1	E				Standard + Ethernet (Copper & Fiber - MTRJ), Modbus TCP/IP, DNP3.0, IEC 60870-5-104
						3	E				Standard + Ethernet (Copper & Fiber - MTRJ), Modbus TCP/IP, DNP3.0, IEC 60870-5-104, IEC 61850
Harsh Environment									N		None
									H		Harsh Environment Conformal Coating

^a Ground current options "G1/G5" must match the corresponding "P1/P5" Phase currents

RMIO	*	G	G	*	*	Description
Power Supply	L					24 - 48 V DC
	H					110 - 250 V DC / 110 - 230 V AC
I/O Module 1		G				Remote Module I/O (3 - 100 Ohm Platinum RTDs)
I/O Module 2			G			Remote Module I/O (3 - 100 Ohm Platinum RTDs)
I/O Module 3				G		Remote Module I/O (3 - 100 Ohm Platinum RTDs)
				X		None
I/O Module 4					G	Remote Module I/O (3 - 100 Ohm Platinum RTDs)
					X	None

Related Products / Accessories

- SR3 Depth reducing collar - 1.375" 18L0-0076
- SR3 Depth reducing collar - 3.00" 18L0-0075
- SR3 IP20 Kit 18L0-0080
- NDO Straight Connector Kit 18L1-0041
- USB A-B configuration cable (6') 0804-0458

GE Grid Solutions

650 Markland St.
Markham, ON
Canada L6C 0M1

Toll Free (NA Only): 1-800-547-8629

Tel: 905-927-7070

Fax: 905-927-5098

GEGridSolutions.com

IEC is a registered trademark of Commission Electrotechnique Internationale.
ANSI is a registered trademark of American National Standards Institute, Incorporated.
IEEE is a registered trademark of the Institute of Electrical Electronics Engineers, Inc.
GE, the GE monogram, Multilin and EnerVista are trademarks of the General Electric Company.

GE reserves the right to make changes to specifications of products described at any time without notice and without obligation to notify any person of such changes.

Copyright 2018, General Electric Company. All Rights Reserved.



imagination at work

GEA-12778NIE
English
180228